

ASSEMBLY INSTRUCTIONS:

Product Code : MRC GW/ZB

Product Name: Marquee Reception

TIME REQUIRED:

40 minutes

TOOLS REQUIRED:

Screwdriver, Electric Drill, Pencil, Measuring tape/Ruler

*Tools are not included.

SKILL REQUIRED:

Easy ●●●●○ Hard

The Assembly Skill Rating is a 5-point system that shows the degree of effort needed in assembling a specific product. With 1 being easy for the average person and 5 requiring an expert. For most products, two persons are recommended.

NOTE

- As this is a commercial product, some intermediate skills may be required.
 - No pre-drill holes or markings are provided on our table or desk tops.
 - Please check you have all hardware before assembling.
- If you are missing any hardware, please contact your Rapidline reseller. Please ensure you have the name of the item, required hardware part and quantity.
 - Please retain your receipt as proof of purchase to validate your warranty.
- Assemble on a clean, flat, smooth surface such as a rug or carpet to avoid parts from being scratched.
 - Remove all wrapping materials, including staples and packing straps before you start to assemble
 - Keep all hardware parts out of reach of children.

CAUTION

- Heavy product. Do not attempt to lift or move without help
- Do not tighten screws and bolts until completely assembled.
- Do not use this product unless all bolts and screws are firmly secured and tightened.

WARNING

- If parts are missing, broken, damaged or worn stop using the product until all repairs are made.
 - Failure to follow these warnings could result in serious injury.

rapidline

Assembly Instructions

MODEL NO.: RC3 RECEPTION DESK

A  54Set	B  54Pcs	C  44Pcs	D  2Pcs	E  Ø80 2Pcs	F  Ø4*30 18Pcs	G  Ø6*12 10Pcs	H  6 Set	I  Ø6*35 6Pcs
---	--	--	---	--	--	---	--	--

STEP1

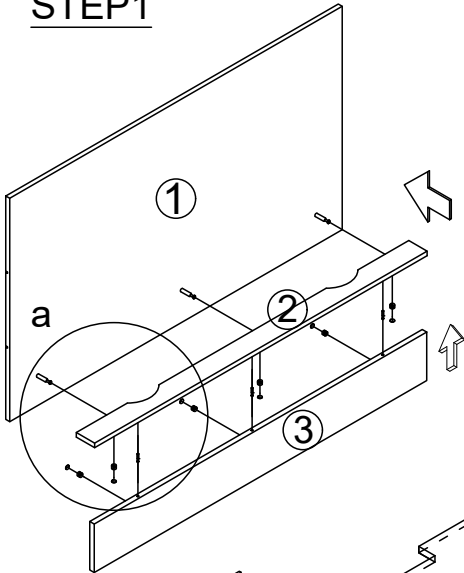

STEP2

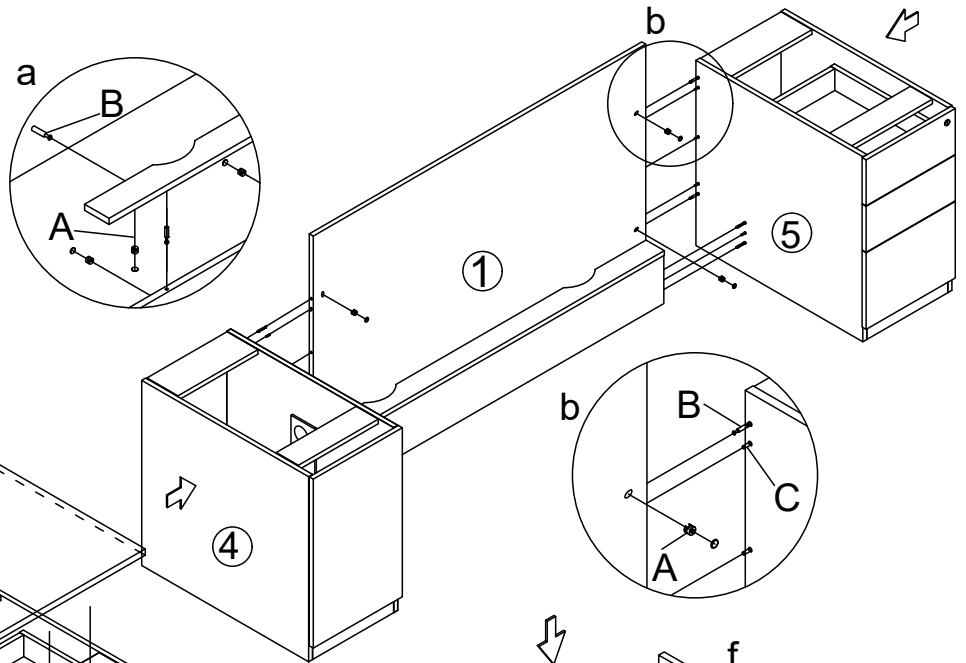

STEP3

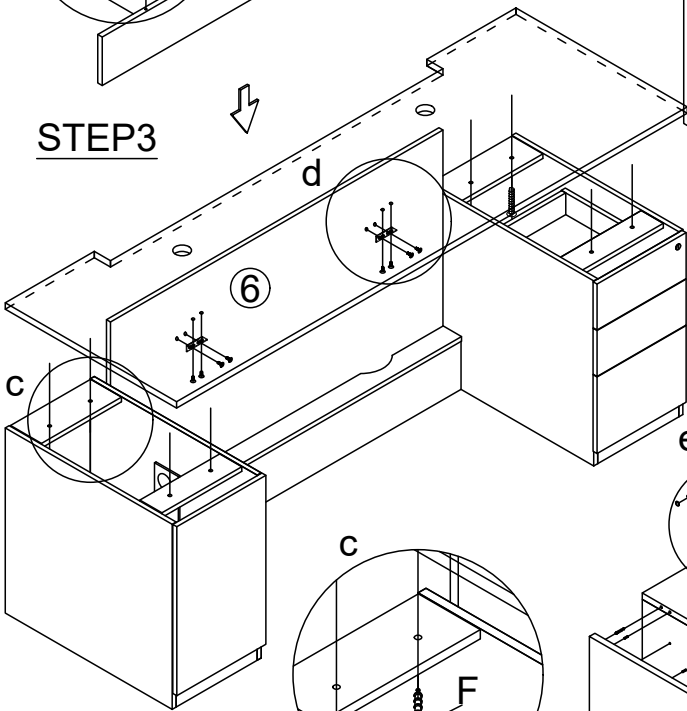

STEP4

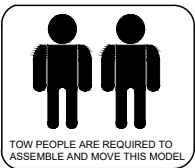
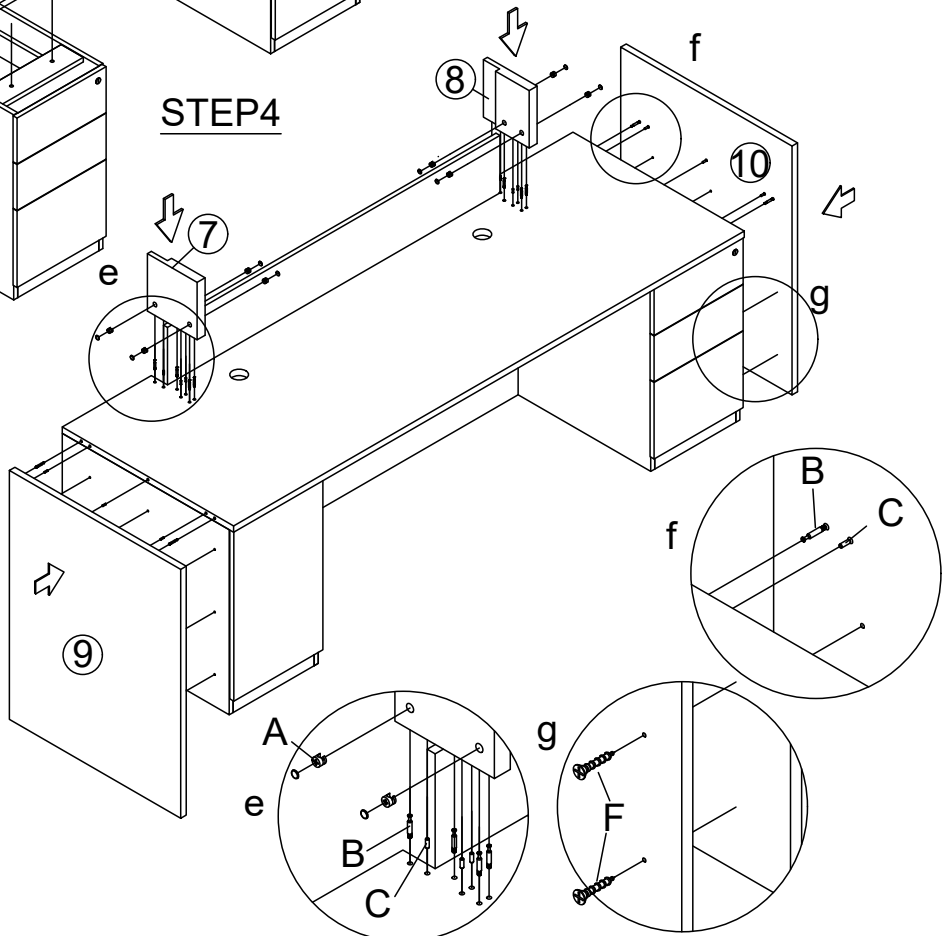

IMPORTANT NOTE:

- Place all parts on a clean and smooth surface such as a rug or carpet to avoid the parts from being scratched.
- Check to be sure that you have all parts and hardware.
- Remove all wrapping materials, including staples & packing straps before you start to assemble.
- Don't tighten all screws/bolts until all completely assembled.
- Keep all hardware parts out of reach of children

Assembly Instructions

MODEL NO.: RC3 RECEPTION DESK

STEP 5

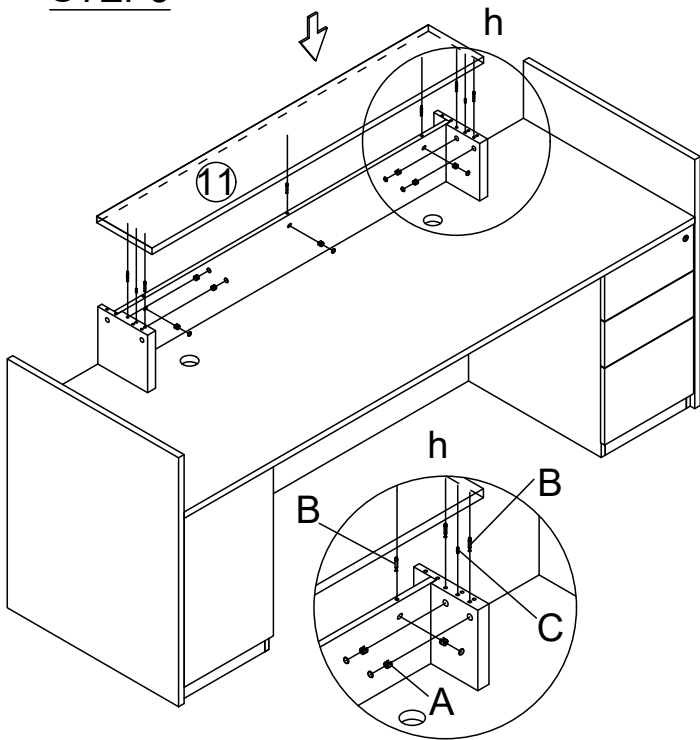

STEP 6

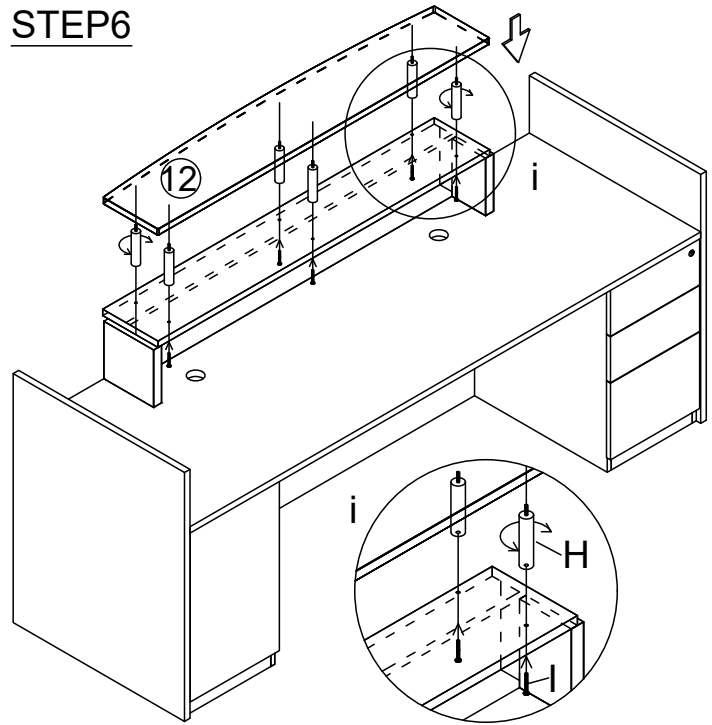

STEP 7

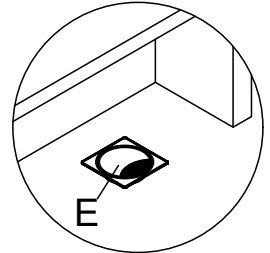
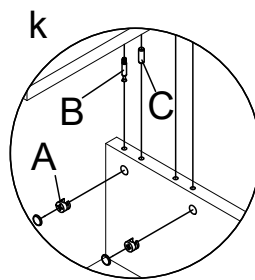
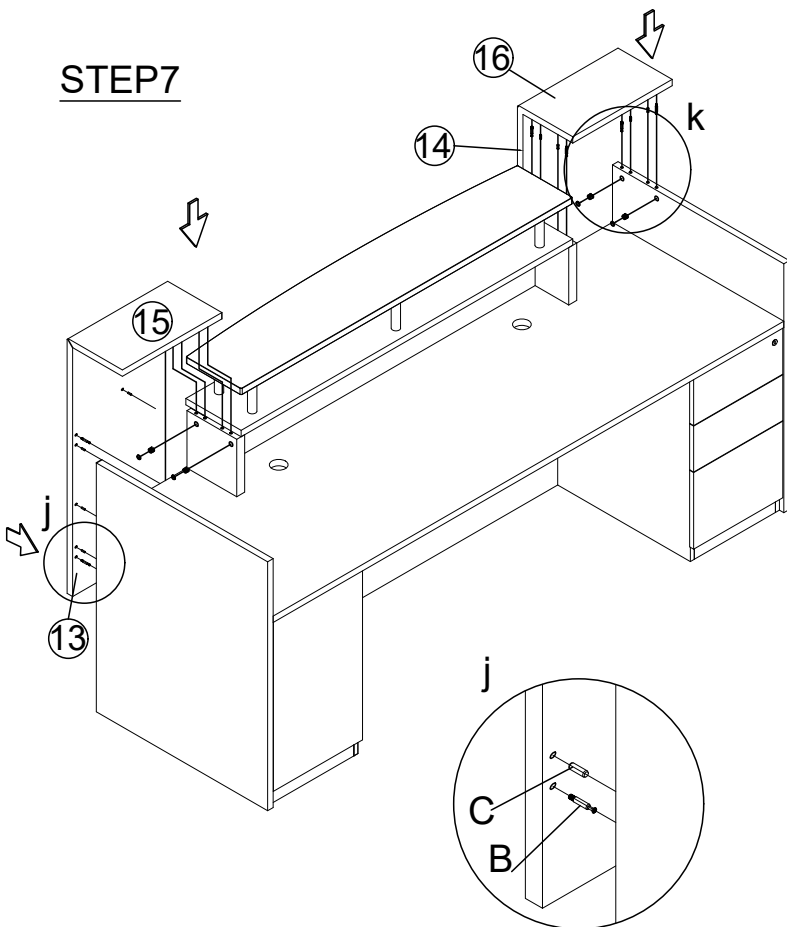

COMPLETED ASSEMBLY

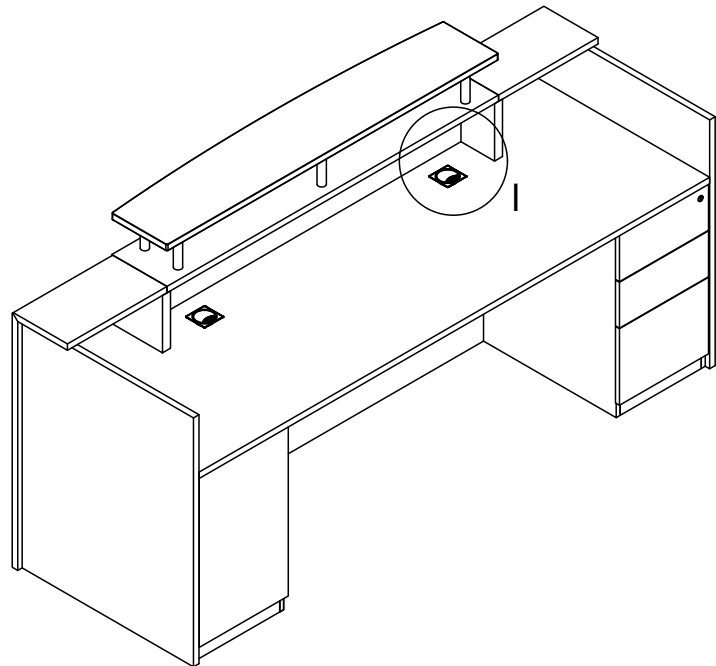

IMPORTANT NOTE:

- Place all parts on a clean and smooth surface such as a rug or carpet to avoid the parts from being scratched.
- Check to be sure that you have all parts and hardware.
- Remove all wrapping materials, including staples & packing straps before you start to assemble.
- Don't tighten all screws/bolts until all completely assembled.
- Keep all hardware parts out of reach of children